

# Methods and Devices for the Prevention of Backflow and Back-Siphonage

A wide choice of devices exists that can be used to prevent backsiphonage and backpressure from adding contaminated fluids or gases into a potable water supply system. Generally, the selection of the proper device to use is based upon the degree of hazard posed by the cross-connection. Additional considerations are based upon piping size, location, and the potential need to periodically test the devices to insure proper operation.

There are six basic types of devices that can be used to correct cross-connections: air gaps, barometric loops, vacuum breakers—both atmospheric and pressure type, double check with intermediate atmospheric vent, double check valve assemblies, and reduced pressure principle devices. In general, all manufacturers of these devices, with the exception of the barometric loop, produce them to one or more of three basic standards, thus insuring the public that dependable devices are being utilized and marketed. The major standards in the industry are: American Society of Sanitary Engineers ASSE), American Water Works Association (AWWA), and the University of California Foundation for Cross-Connection Control and Hydraulic Research.

## Air Gap

Air gaps are non-mechanical backflow preventers that are very effective devices to be used where either backsiphonage or backpressure conditions may exist. Their use is as old as piping and plumbing itself, but only relatively recently have standards been issued that standardize their design. In general, the air gap must be twice the supply pipe diameter but never less than one inch. See Figure 12.

FIGURE 12. Air gap.

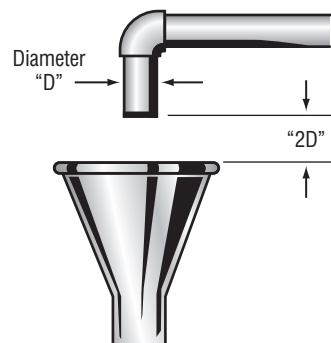

An air gap, although an extremely effective backflow preventer when used to prevent backsiphonage and backpressure conditions, does interrupt the piping flow with corresponding loss of pressure for subsequent use. Consequently, air gaps are primarily used at end of the line service where reservoirs or storage tanks are desired. When contemplating the use of an air gap, some other considerations are:

(1) In a continuous piping system, each air gap requires the added expense of reservoirs and secondary pumping systems.

(2) The air gap may be easily defeated in the event that the “2D” requirement was purposely or inadvertently compromised. Excessive splash may be encountered in the event that higher than anticipated pressures or flows occur. The splash may be a cosmetic or true potential hazard—the simple solution being to reduce the “2D” dimension by thrusting the supply pipe into the receiving funnel. By so doing, the air gap is defeated.

(3) At an air gap, we expose the water to the surrounding air with its inherent bacteria, dust particles, and other airborne pollutants or contaminants. In addition, the aspiration effect of the flowing water can drag down surrounding pollutants into the reservoir or holding tank.

(4) Free chlorine can come out of treated water as a result of the air gap and the resulting splash and churning effect as the water enters the holding tanks. This reduces the ability of the water to withstand bacteria contamination during long term storage.

(5) For the above reasons, air gaps must be inspected as frequently as mechanical backflow preventers. They are not exempt from an in-depth cross-connection control program requiring periodic inspection of all backflow devices.

Air gaps may be fabricated from commercially available plumbing components or purchased as separate units and integrated into plumbing and piping systems. An example of the use of an air gap is shown in Figure 13.

FIGURE 13.  
Air gap in a piping system.

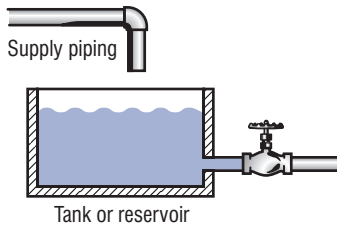

### Barometric Loop

The barometric loop consists of a continuous section of supply piping that abruptly rises to a height of approximately 35 feet and then returns back down to the originating level. It is a loop in the piping system that effectively protects against backsiphonage. It may not be used to protect against backpressure.

Its operation, in the protection against backsiphonage, is based upon the principle that a water column, at sea level pressure, will not rise above 33.9 feet (Ref. Chapter 3, Fig. 4 Page 13).

In general, barometric loops are locally fabricated, and are 35 feet high.

FIGURE 14.  
Barometric loop.

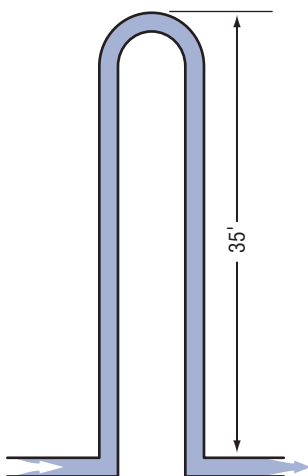

### Atmospheric Vacuum Breaker

These devices are among the simplest and least expensive mechanical types of backflow preventers and, when installed properly, can provide excellent protection against backsiphonage. They must not be utilized to protect against backpressure conditions.

Construction consists usually of a polyethylene float which is free to travel on a shaft and seal in the uppermost position against atmosphere with an elastomeric disc. Water flow lifts the float, which then causes the disc to seal. Water pressure keeps the float in the upward sealed position. Termination of the water supply will cause the disc to drop down venting the unit to atmosphere and thereby opening downstream piping to atmospheric pressure, thus preventing backsiphonage. Figure 15 shows a typical atmospheric breaker.

In general, these devices are available in 1/2-inch through 3-inch size and must be installed vertically, must not have shutoffs downstream, and must be installed at least 6-inches higher than the final outlet. They cannot be tested once they are installed in the plumbing system, but are, for the most part, dependable, trouble-free devices for backsiphonage protection.

FIGURE 15.  
Atmospheric vacuum breaker.

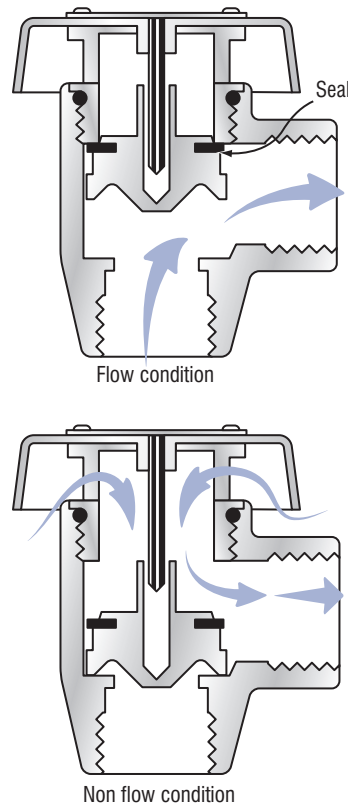

FIGURE 16.  
Atmospheric vacuum breaker typical installation.

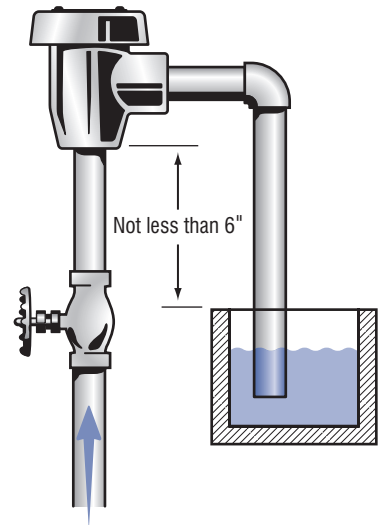

FIGURE 17.  
Atmospheric vacuum breaker in plumbing supply system.

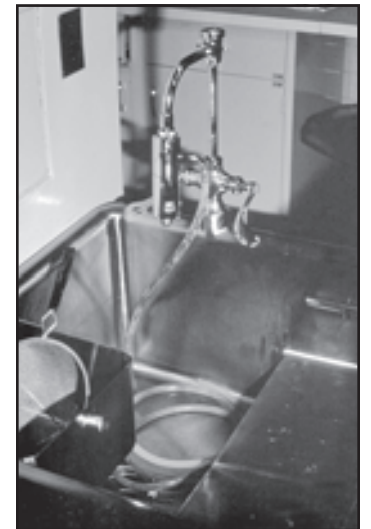

Figure 16 shows the generally accepted installation requirements—note that no shutoff valve is downstream of the device that would otherwise keep the atmospheric vacuum breaker under constant pressure.

Figure 17 shows a typical installation of an atmospheric vacuum breaker in a plumbing supply system.

## Hose Bibb Vacuum Breakers

These small devices are a specialized application of the atmospheric vacuum breaker. They are generally attached to sill cocks and in turn are connected to hose supplied outlets such as garden hoses, sloop sink hoses, spray outlets, etc. They consist of a spring loaded check valve that seals against an atmospheric outlet when water supply pressure is turned on. Typical construction is shown in Figure 18.

When the water supply is turned off, the device vents to atmosphere, thus protecting against backsiphonage conditions. They should not be used as backpressure devices. Manual drain options are available, together with tamper-proof versions. A typical installation is shown in Figure 19.

FIGURE 19. Typical installation of hose bibb vacuum breaker.

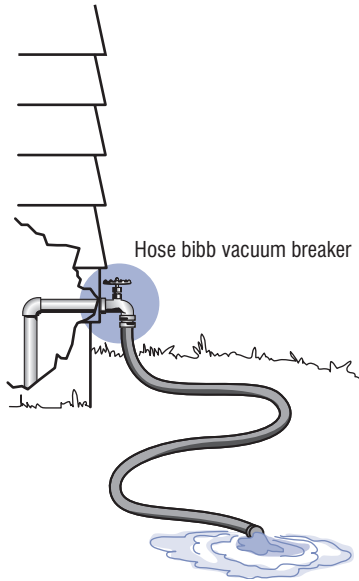
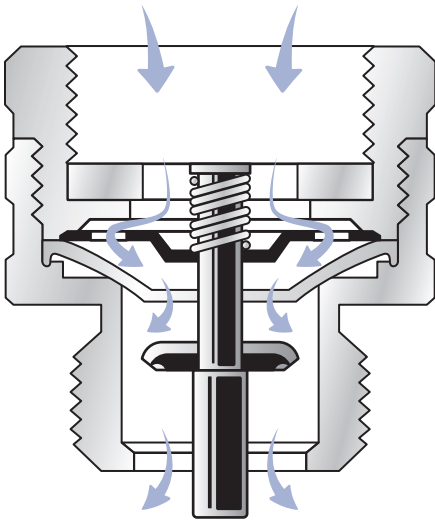

FIGURE 18. Hose bibb vacuum breaker.



## Pressure Vacuum Breakers

This device is an outgrowth of the atmospheric vacuum breaker and evolved in response to a need to have an atmospheric vacuum breaker that could be utilized under constant pressure and that could be tested in line. A spring on top of the disc and float assembly, two added gate valves, test cocks, and an additional first check, provided the answer to achieve this device. See Figure 20.

These units are available in the general configurations as shown in Figure 20 in sizes 1/2-inch through 10-inch and have broad usage in the agriculture and irrigation market. Typical agricultural and

industrial applications are shown in Figure 21.

Again, these devices may be used under constant pressure but do not protect against backpressure conditions. As a result, installation must be at least 6- to 12-inches higher than the existing outlet.

A spill resistant pressure vacuum vacuum breaker (SVB) is available that is a modification to the standard pressure vacuum breaker but specifically designed to minimize water spillage. Installation and hydraulic requirements are similar to the standard pressure vacuum breaker and the devices are recommended for internal use.

FIGURE 20. Pressure vacuum breaker

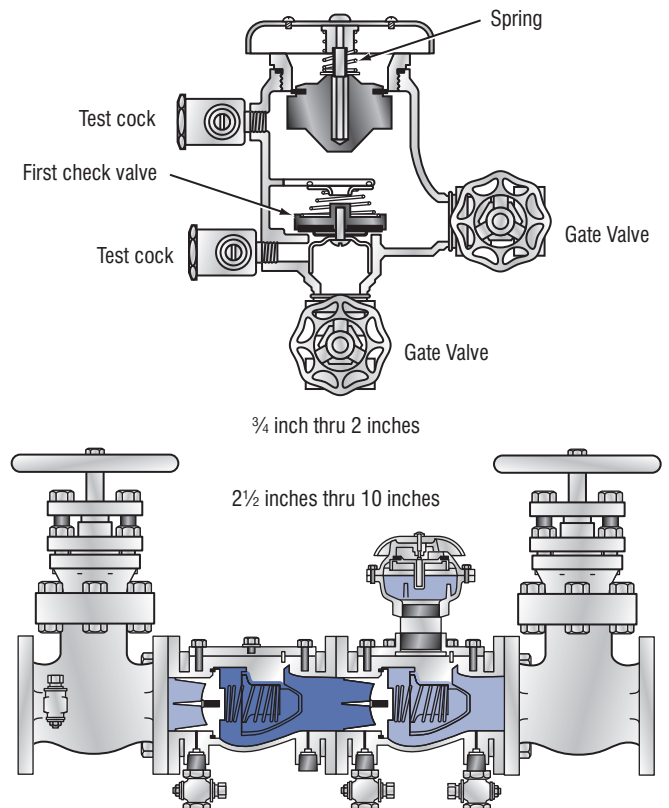

## Double Check with Intermediate Atmospheric Vent

The need to provide a compact device in 1/2-inch and 3/4-inch pipe sizes that protects against moderate hazards, is capable of being used under constant pressure and that protects against backpressure, resulted in this unique backflow preventer. Construction is basically a double check valve having an atmospheric vent located between the two checks (See Figure 22).

Line pressure keeps the vent closed, but zero supply pressure or backsiphonage will open the inner chamber to atmosphere. With this device, extra protection is obtained through the atmospheric vent capability. Figure 23 shows a typical use of the device on a residential boiler supply line.

FIGURE 21. Typical agricultural and industrial application of pressure vacuum breaker.

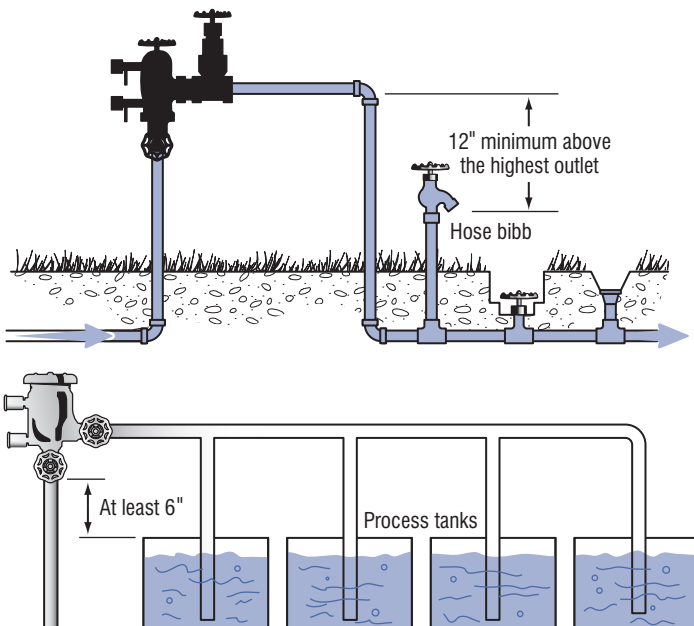

FIGURE 22. Double check valve with atmospheric vent.

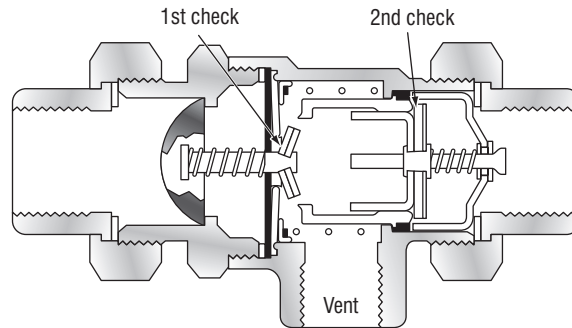
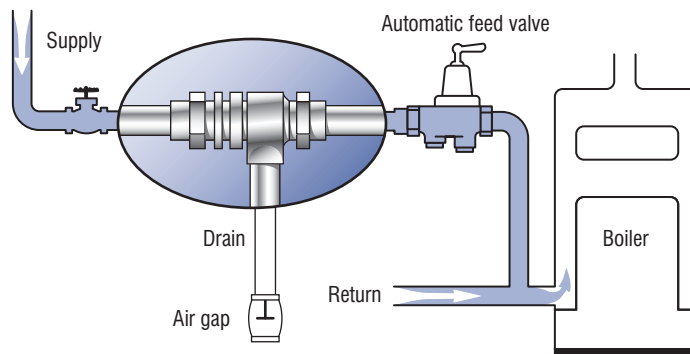

FIGURE 23. Typical residential use of double check with atmospheric vent.



## Double Check Valve

A double check valve is essentially two single check valves coupled within one body and furnished with test cocks and two tightly closing gate valves (See Figure 24).

The test capability feature gives this device a big advantage over the use of two independent check valves in that it can be readily tested to determine if either or both check valves are inoperative or fouled by debris. Each check is spring loaded closed and requires approximately a pound of pressure to open.

This spring loading provides the ability to “bite” through small debris and still seal—a protection feature not prevalent in unloaded swing check valves. Figure 24 shows a cross section of double check valve complete with test cocks. Double checks are commonly used to protect against low to medium hazard installations such as food processing steam kettles and apartment projects. They may be used under continuous pressure and protect against both backsiphonage and backpressure conditions.

FIGURE 24. Double check valve.

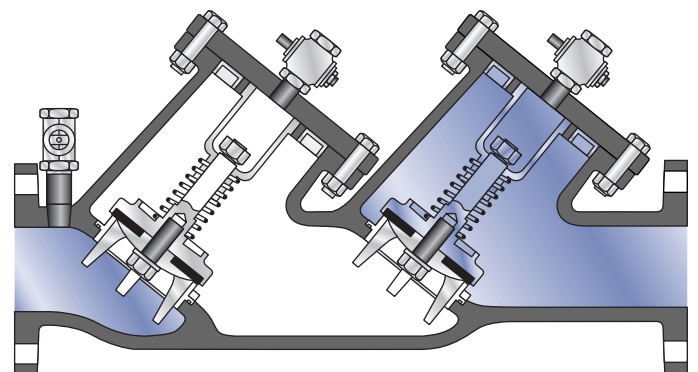

## Double Check Detector Check

This device is an outgrowth of the double check valve and is primarily utilized in fire line installations. Its purpose is to protect the potable supply line from possible contamination or pollution from fire line chemical additives, booster pump fire line backpressure, stagnant “black water” that sits in fire lines over extended periods of time, the addition of “raw” water through outside fire pumper connections (Siamese outlets), and the detection of any water movement in the fire line water due to fire line leakage or deliberate water theft. It consists of two, spring loaded check valves, a bypass assembly with water meter and double check valve, and two tightly closing gate valves. See Figure 25. The addition of test cocks makes the device testable

to insure proper operation of both the primary checks and the bypass check valve. In the event of very low fire line water usage, (theft of water) the low pressure drop inherent in the bypass system permits the low flow of water to be metered through the bypass system. In a high flow demand, associated with deluge fire capability, the main check valves open, permitting high volume, low restricted flow, through the two large spring loaded check valves.

FIGURE 25.  
Double check detector check.

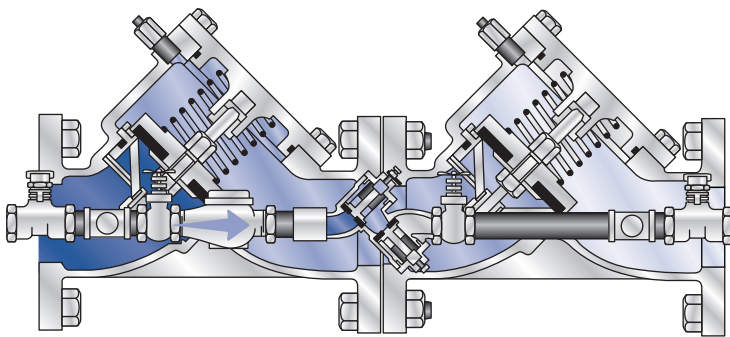

## Residential Dual Check

The need to furnish reliable and inexpensive backsiphonage and backpressure protection for individual residences resulted in the debut of the residential dual check. Protection of the main potable supply from household hazards such as home photograph chemicals, toxic insect and garden sprays, termite control pesticides used by exterminators, etc., reinforced, a true need for such a device. Figure 26 shows a cutaway of the device.

It is sized for 1/2-, 3/4-, and 1-inch service lines and is installed immediately downstream of the water meter. The use of plastic check modules and elimination of test cocks and gate valves keeps the cost reasonable while providing good, dependable protection. Typical installations are shown in Figures 27 and 28.

FIGURE 26.  
Residential dual check.

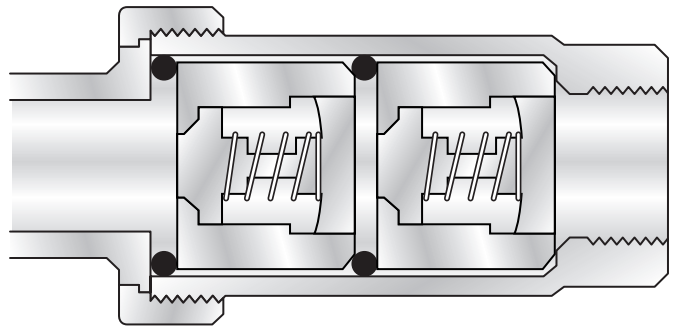

FIGURE 27.  
Residential installation.

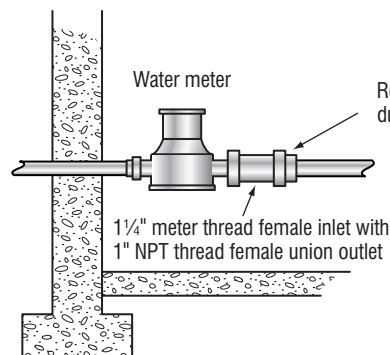
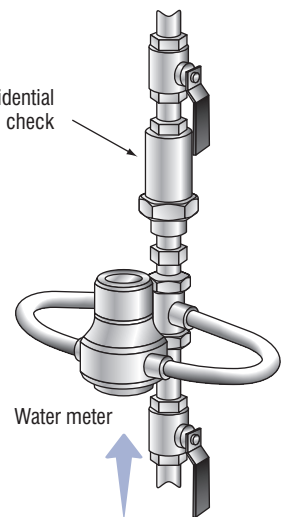

FIGURE 28.  
Copper horn.



## Reduced Pressure Principle Backflow Preventer

Maximum protection is achieved against backsiphonage and backpressure conditions utilizing reduced pressure principle backflow preventers. These devices are essentially modified double check valves with an atmospheric vent capability placed between the two checks and designed such that this “zone” between the two checks is always kept at least two pounds less than the supply pressure. With this design criteria, the reduced pressure principle backflow preventer can provide protection against backsiphonage and backpressure when both the first and second checks become fouled. They can be used under constant pressure and at high hazard installations. They are furnished with test cocks and gate valves to enable testing and are available in sizes  $\frac{3}{4}$ -inch through 10 inch.

Figure 29A shows typical devices representative of  $\frac{3}{4}$ -inch through 2-inch size and Figure 29B shows typical devices representative of  $2\frac{1}{2}$ -inch through 10-inch sizes.

FIGURE 29A.  
Reduced pressure zone backflow preventer ( $\frac{3}{4}$ -inch thru 2-inches).

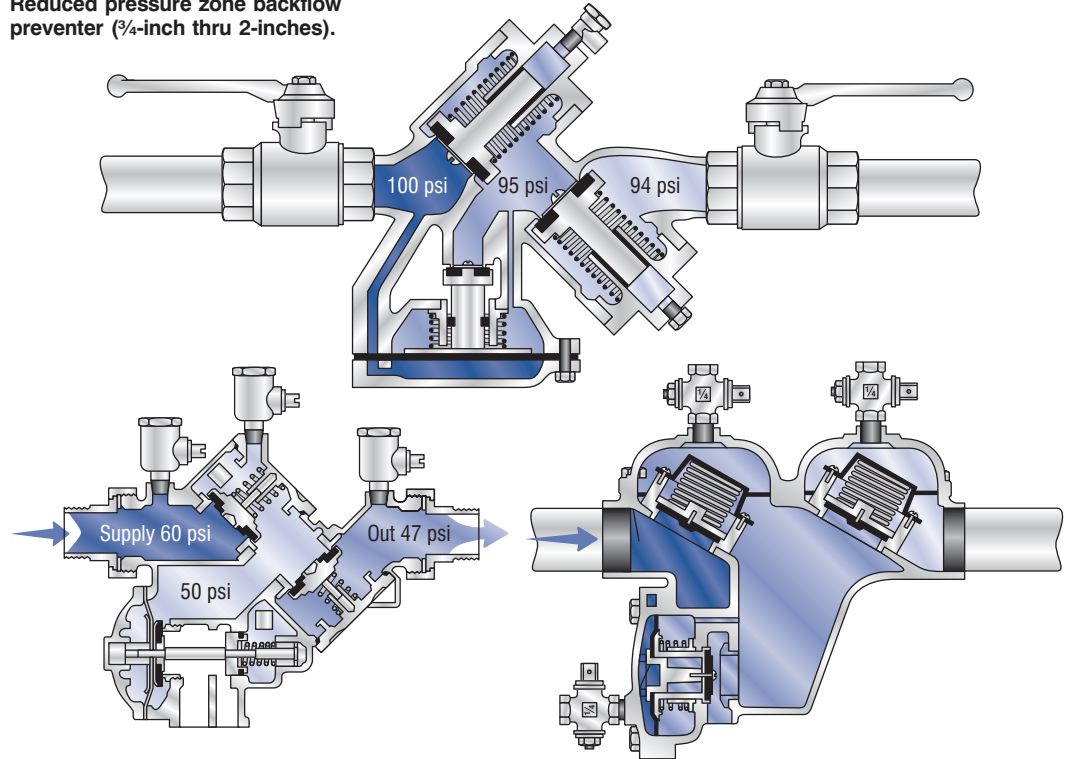
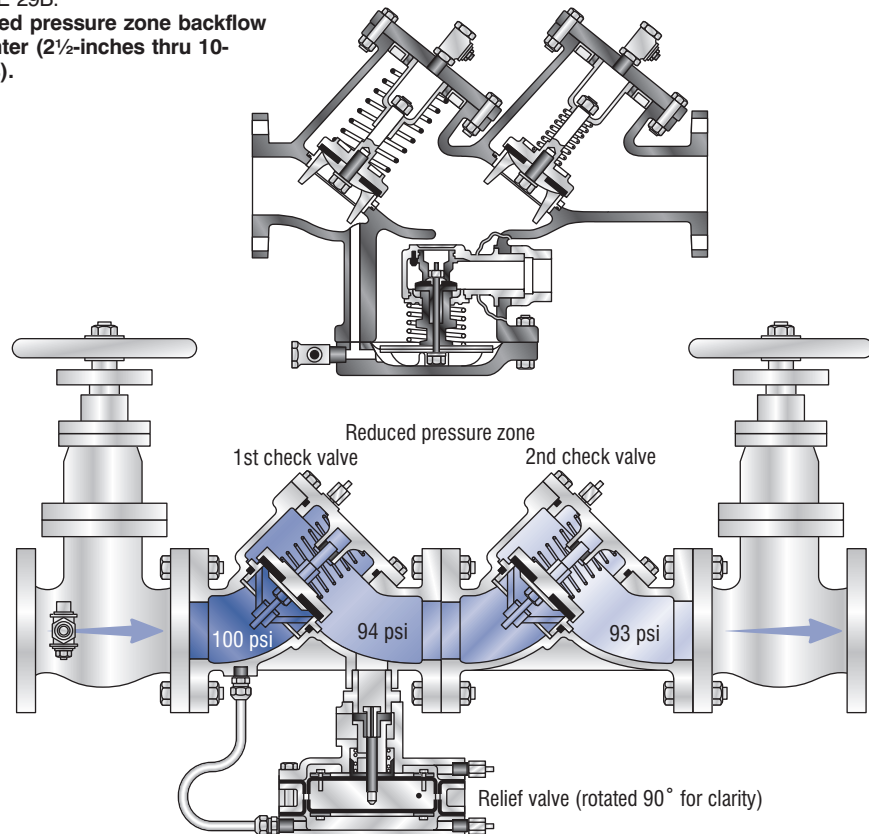

FIGURE 29B.  
Reduced pressure zone backflow preventer ( $2\frac{1}{2}$ -inches thru 10-inches).



The principles of operation of a reduced pressure principle backflow preventer are as follows:

Flow from the left enters the central chamber against the pressure exerted by the loaded check valve 1. The supply pressure is reduced thereupon by a predetermined amount. The pressure in the central chamber is maintained lower than the incoming supply pressure through the operation of the relief valve 3, which discharges to the atmosphere whenever the central chamber pressure approaches within a few pounds of the inlet pressure. Check valve 2 is lightly loaded to open with a pressure drop of 1 psi in the direction of flow and is independent of the pressure required to open the relief valve. In the event that

the pressure increases downstream from the device, tending to reverse the direction of flow, check valve 2 closes, preventing backflow. Because all valves may leak as a result of wear or obstruction, the protection provided by the check valves is not considered sufficient. If some obstruction prevents check valve 2 from closing tightly, the leakage back into the central chamber would increase the pressure in this zone, the relief valve would open, and flow would be discharged to the atmosphere.

When the supply pressure drops to the minimum differential required to operate the relief valve, the pressure in the central chamber should be atmospheric. If the inlet pressure should become less than atmospheric pressure,

relief valve 3 should remain fully open to the atmosphere to discharge any water which may be caused to backflow as a result of backpressure and leakage of check valve 2.

Malfunctioning of one or both of the check valves or relief valve should always be indicated by a discharge of water from the relief port. Under no circumstances should plugging of the relief port be permitted because the device depends upon an open port for safe operation. The pressure loss through the device may be expected to average between 10 and 20 psi within the normal range of operation, depending upon the size and flow rate of the device.

Reduced pressure principle backflow preventers are commonly installed on high

hazard installations such as plating plants, where they would protect against primarily backsiphonage potential, car washes where they would protect against backpressure conditions, and funeral parlors, hospital autopsy rooms, etc. The reduced pressure principle backflow preventer forms the backbone of cross-connection control programs. Since it is utilized to protect against high hazard installations, and since high hazard installations are the first consideration in protecting public health and safety, these devices are installed in large quantities over a broad range of plumbing and water works installations. Figures 31 and 32 show typical installations of these devices on high hazard installations.

FIGURE 30.  
Reduced pressure zone backflow preventer — principle of operation.

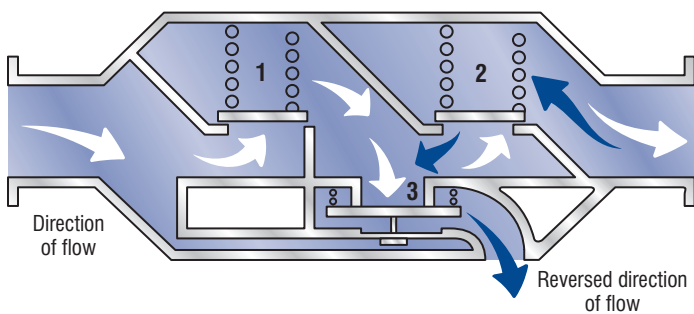

FIGURE 31.  
Plating plant installation.

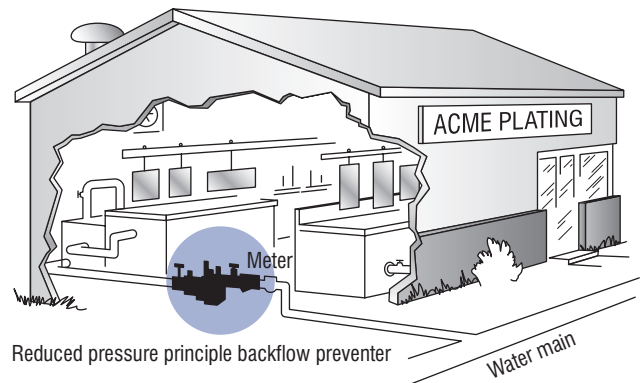
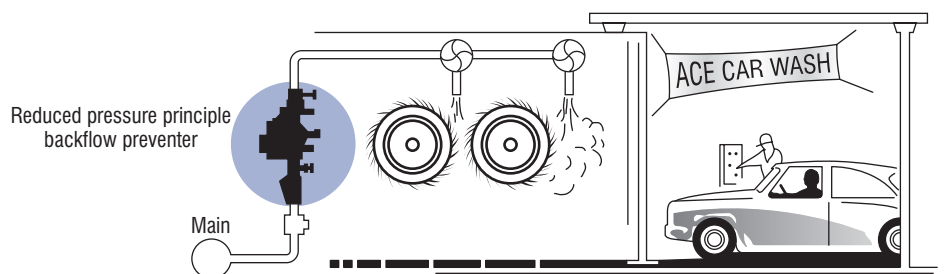
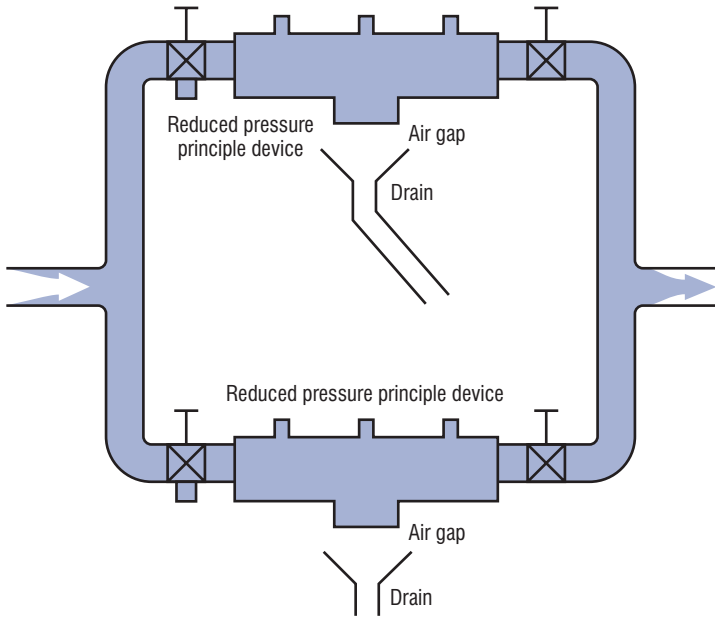

FIGURE 32.  
Car wash installation.

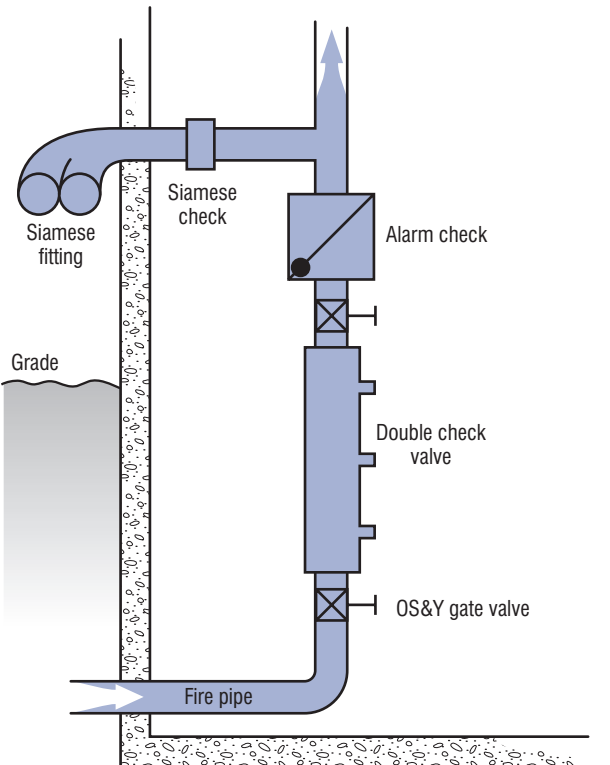

**FIGURE 33.**  
**Typical bypass configuration**  
**reduced pressure principle**  
**devices**



Note: Devices to be set a min. of 12" and a max. of 30" from the floor and 12" from any wall.

**Typical fire line installation double**  
**check valve vertical installation.**



**FIGURE 34.**  
**Typical installation reduced**  
**pressure principle device**  
**horizontal illustration.**

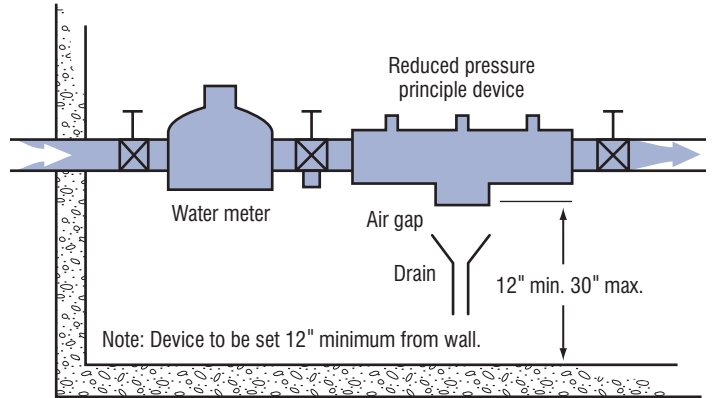

**FIGURE 35.**  
**Typical installation reduced**  
**pressure principle device vertical**  
**illustration.**

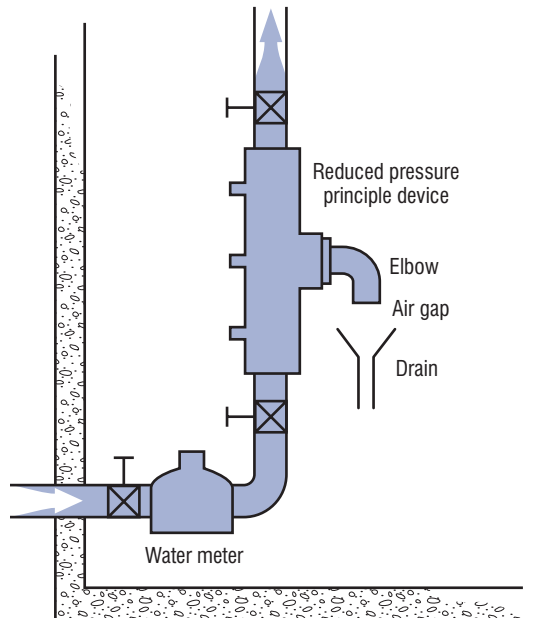

Note: (1) Refer to manufacturers installation data for vertical mount.  
 (2) Unit to be set at a height to permit ready access for testing and service.  
 (3) Vertical installation only to be used if horizontal installation cannot be achieved.



FIGURE 36.  
**Typical installation double check valve horizontal and vertical installation.**

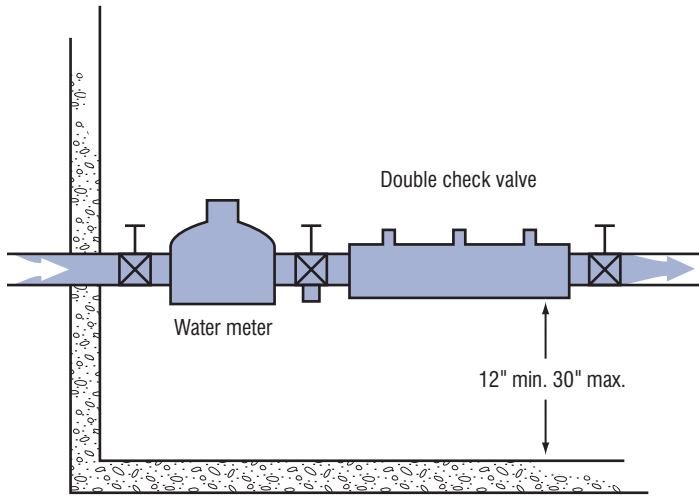
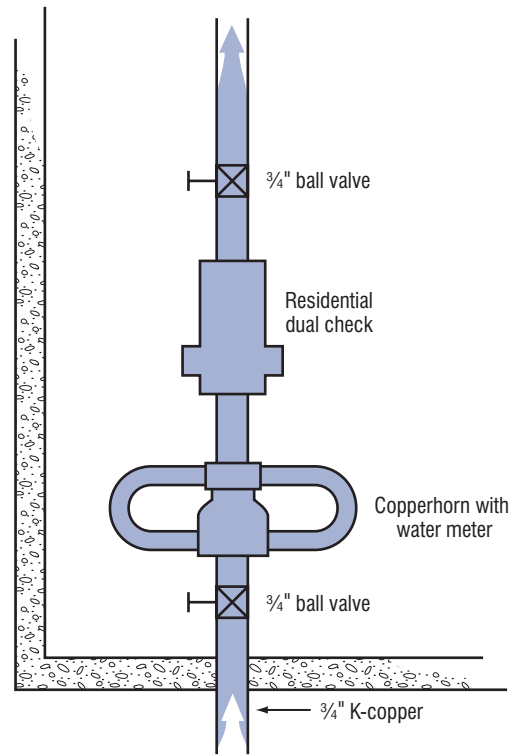
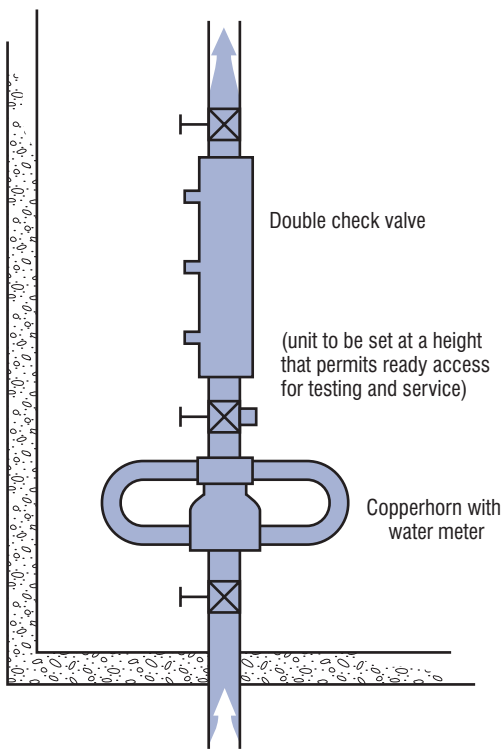
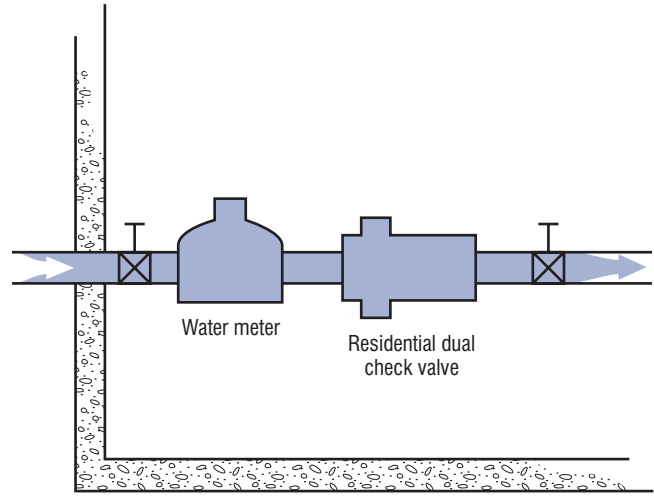

FIGURE 37.  
**Typical installation residential dual check with straight set and copperhorn.**



Note: Vertical installation only to be used if horizontal installation cannot be achieved.